

ISUZU F110.210

11.00T GVW

(Manual transmission) 4x2 rigid

EURO VI

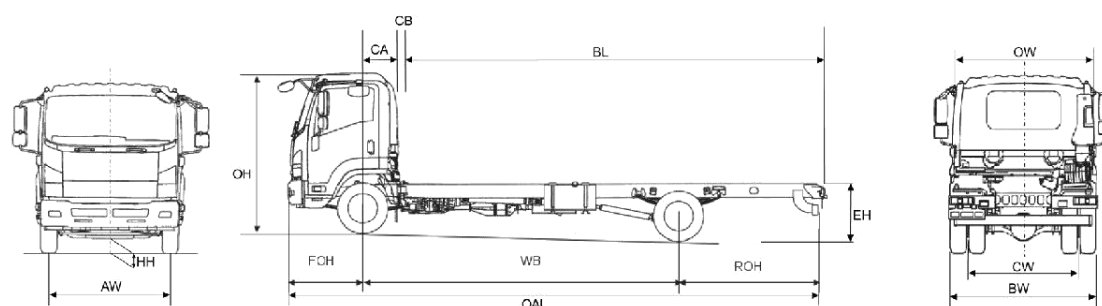
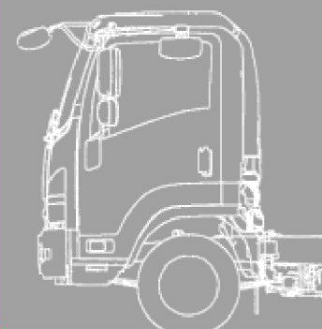

Standard vehicle plated weights (kg)

GVW	11000
GTW	14500

Axle design weights (kg)

Front	4000
Rear	7600

Weights (kg)

Cab type		day	day	day
Wheelbase	WB	4060	4660	4990
Vehicle Mass Unladen	Front	2270	2290	2310
	Rear	1210	1230	1250
Total		3480	3520	3560
GVW		11000	11000	11000
Max. Permissible Trailer Weight		3500	3500	3500
Body & Payload Allowance		7520	7480	7440

Dimensions (mm)

Overall Length	OAL	7000	7900	8350
Overhang - Front	FOH	1170	1170	1170
Overhang - Rear	ROH	1770	2070	2190
Cab Gap	CB	150	150	150
C/L Front Axle to Rear of Cab	CA	556	556	556
Recommended Body Length	BL	5468	6368	6818
Chassis Frame Width		840	840	840
Recommended Body Width		2550	2550	2550
Recommended Maximum Body Width		2600*	2600*	2600*
Cab Width	OW	2200	2200	2200
Overall Height (Unladen)	OH	2510	2510	2505
Chassis Height (Unladen)	EH	875	930	930
Minimum Road Clearance	HH	165	165	165
Track - Front	AW	1795	1795	1795
Track - Rear	CW	1660	1660	1660
Rear Axle Width	BW	2170	2170	2170

*Max dimension for refrigerated bodies only

1. Unladen weights excludes driver, fuel, Ad Blue. Includes spare wheel + carrier (Tolerance $\pm 3\%$).
2. Body lengths are given as a guide only. Bodybuilders are responsible for ensuring all legal requirements are met.
3. Maximum body lengths are calculated to remain within the maximum permitted overhang of 60% of the wheelbase. Cab gaps may vary.
4. Isuzu Truck (UK) Ltd. shall have no liability whatsoever should the information supplied have incorrect data, descriptions or illustrations.

ISUZU

ISUZU F110.210

11.00T GVW

(Manual transmission) 4x2 rigid

EURO VI

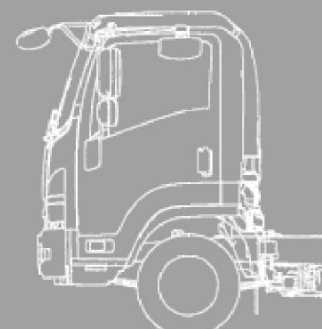

Mechanical Specification (standard equipment)

Engine 4HK1E6S

Isuzu turbo intercooled
OHC 4 cylinder diesel
(Euro VI)
Bore: 115mm
Stroke: 125mm
Capacity: 5193cc
Max Power: 154kW
(210 PS) at 2400rpm
Max Torque: 706Nm at
1600rpm

Injection Type: Common
rail

Euro VI Compliance:
EGR (Exhaust Gas
Recirculation) with
DPD (Diesel Particulate
Diffuser) SCR Adblue and
OBD

Fuel Tank

Capacity: 140 litres
Ad Blue: 16 litres

Transmission

6 speed Isuzu Manual
MZW6P gearbox

Ratios: 1st	6.615
2nd	4.095
3rd	2.358
4th	1.531
5th	1.000
6th	0.722
reverse	6.615

Rear Axle Ratio: 4.555:1
Tyres: 235/75 17.5 radial
Wheels: Steel 17.5 x 6.75,
6-stud

Cab Exterior

Aerodynamic Isuzu
Hexapod design white
all steel w ith roof outline
markers
Tilt to 45 deg.
Keyless door entry and
immobiliser
Laminated w indscreen
Non-slip entry steps
90 deg. opening doors
Zinc galvanised frame
structure
2 halogen headlamp units
w ith indicators
Front mudguards w ith
spray suppression
All-steel front bumper
w ith fog and daytime
running lamps
Chrome radiator grille
Aluminium rear bumper

Frame

Parallel ladder type
channel section

Cooling

Tube and fin type
radiator w ith fan and
viscous clutch
Frame mounted fuel
cooler

Clutch

Automatically adjusted,
air assisted 356mm
diameter

Cab Interior

Flame-resistant interior
trim
Vinyl floor matting
Dual long grab handles
each side
SRS airbags driver and
passenger
Header console storage
Interior fluorescent
lighting

Seats (all cloth)

Driver's adjustable
air-suspended seat
w ith head restraint and
3-point seat belt w ith pre-
tensioner
Rigid centre seat w ith
2-point seatbelt
Rigid passenger seat
w ith head restraint and
3-point seat belt pre-
tensioner

Vision

Large door mounted
heated mirrors
Front underview mirror
and kerb mirror
Driver and passenger sun
visors
Deep cut side w indow s to
reduce blind spots
Electric w indow s w ith
driver control and lock
w ith indicators

Heating & Ventilation

4-Speed blow er
Multiple cab vents

Axles

Front: Reverse Elliott
I-Beam
Rear: Banjo type, fully
floating

Suspension

Front: Multi Taper-leaf
steel springs
Rear: Multi Taper-leaf
steel springs w ith helper

Steering

Recirculating ball type
w ith full integral hydraulic
pow er assistance
Tilt and telescopic
steering column

Brakes

System: ABS air over
hydraulic, dual circuit
w ith anti-slip regulation,
Front: Drum 320mm x
120mm
Rear: Drum 320mm x
145mm
Park: Rear Wheel
Air dryer

Instruments

Rev counter
Tachograph, digital
Siemens VDO
Speedometer w ith
odometer and trip
Multi-information
display provides data on
servicing emissions and
fuel economy
Gauges: Fuel level,
coolant temperature and
air pressure

Switches & Electrical

Electrical vehicle speed
limiter set at 56mph
(90kph) w ith automatic
cruise control
Steering column mounted
sw itch for indicators, side
lights, headlights, high
beam, front and rear fog
lamps
Wiper and washer
(2-speed and
intermittent)
Exhaust brake
Brake w arning buzzer
Steering wheel horn
Hazard lights
Headlamp levelling
Interior light
Key operation for quick
cold start, start and stop
Cigarette lighter

Central locking
Reverse w arning

DPD engage
Engine idle control
Heated mirrors
Engine quick w arm-up
ASR off
Heater stage

Warning /Indicator Lamps

Battery charge
Oil pressure
Brake system
Low fuel
Glow plug operation
High beam indicators
Parking brake on
Exhaust brake operation
Fuel/w ater separator
Check engine
ABS
SVS
DPD operation
OBD
Front and rear fog
Air pressure w arning
Engine over heat
Adblue level
Seat belt
SRS air bag

Tool Kit

Jack w ith a small
selection of hand tools

Radio

DAB radio w ith CD player

Storage Space

Centre seat back
compartment
Door pockets
Tw in overhead lockers
Centre tray
Dashboard pockets
Card holder

Ancillaries

Starter: 24 V x 4.5kW
Alternator: 24 V - 90 Amp
Quick Start: 4 glow plugs
on start relay
Battery: 2 x 12 V - 115 AH

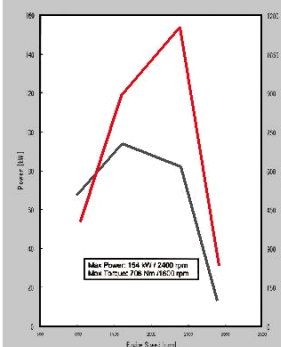
**The following optional items are available:**

- Isuzu Branded Mats
- Aerodynamic Body Kits
- Satellite Navigation
- Reversing Aids
- PTO Sw itch
- Telematics

For further information
please contact your local
dealer, ring us directly on

01 4194500
or visit our website
www.isuzu-ireland.com

Isuzu Ireland,
Naas Road
Dublin 12

ISUZU

