

PROVISIONAL

ISUZU N35.150 (TE)

3.5T GVW

(Easyshift transmission) 4x2 rigid twin rear wheels

EURO VI

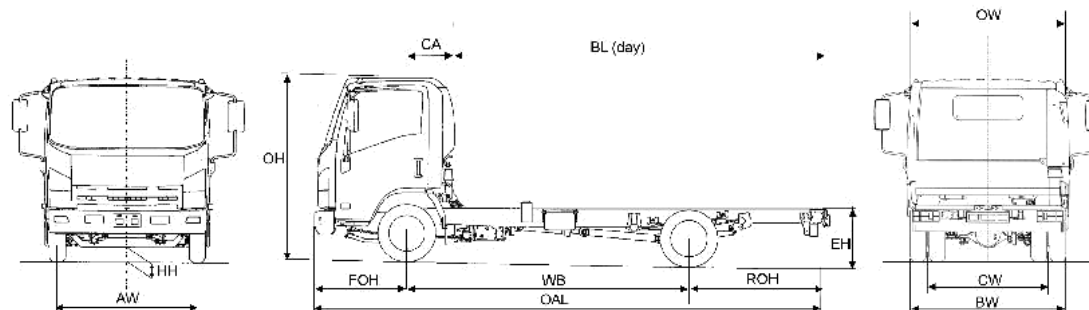

Standard vehicle plated weights (kg)

GVW	3500
GTW	7000

Axle design weights (kg)

Front	2100
Rear	2435

Weights (kg)

Cab type		day
Wheelbase	WB	3350
Vehicle Mass Unladen	Front	1505
	Rear	640
Total		2145
GVW		3500
Max. Permissible Trailer Weight		3500
Body & Payload Allowance		1355

Dimensions (mm)

Overall Length	OAL	6025
Overhang - Front	FOH	1110
Overhang - Rear	ROH	1565
Cab Gap	CB	130
C/L Front Axle to Rear of Cab	CA	463
Recommended Body Length	BL	4267
Chassis Frame Width		700
Recommended Body Width		1982
Recommended Maximum Body Width		2160
Cab Width	OW	1770
Overall Height (Unladen)	OH	2160
Chassis Height (Unladen)	EH	725
Minimum Road Clearance	HH	190
Track - Front	AW	1475
Track - Rear	CW	1425
Rear Axle Width	BW	1855

1. Unladen weights include driver 75kg, 90% fuel. (Tolerance $\pm 3\%$).

2. Body lengths are given as a guide only. Bodybuilders are responsible for ensuring all legal requirements are met.

3. Maximum body lengths are calculated to remain within the maximum permitted overhang of 60% of the wheelbase. Cab gaps may vary.

4. Isuzu Ireland shall have no liability whatsoever should the information supplied have incorrect data, descriptions or illustrations.

PROVISIONAL

ISUZU N35.150(TE)

3.5T GVW

(Easyshift transmission) 4x2 rigid twin rear wheels

EURO VI

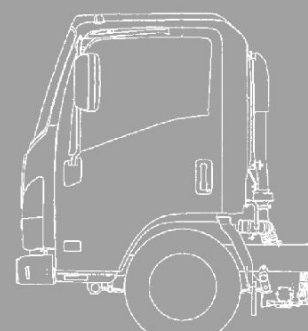

Mechanical Specification (standard equipment)

Engine 4JJ1TC

Isuzu turbo intercooled DOHC 4 cylinder diesel (Euro VI)

Bore: 95.4mm

Stroke: 104.9mm

Capacity: 2999cc

Max Power: 110kW

(150 PS) at 2800rpm

Max Torque: 375Nm

between 1600-

2800rpm

Injection

Type: Common rail

Euro VI Compliance:

EGR (Exhaust Gas

Recirculation) with DPD

(Diesel Particulate

Diffuser), SCR Adblue

and OBD

Fuel Tank

Capacity: 90 litres

Transmission

5-speed MYY5T with fully automated and sequential shift modes

Ratios: 1st 5.315:1

2nd 5.315:1

3rd 1.655:1

4th 1.000:1

5th 0.721:1

reverse 5.068:1

Rear Axle Ratio: 3.909:1

Tyres: 205/75 R16C radial

Wheels: 5.50J x 16, 5-stud

Cab Exterior

Aerodynamic Isuzu

Hexapod design

white all-steel

Manual tilt to 45 deg

Laminated windscreen

Plastic resin non-slip

entry steps

90 deg. opening

doors Zinc galvanised

frame structure

2 flush mounted halogen

headlamps with side

mounted indicators

Front tyre mudguards

with spray suppression

Steel reinforced composite

front bumper with fog

and daytime running lamps

Chrome radiator grille

Keyless door entry and

immobiliser

Steel rear bumper

Frame

Ladder type channel section straight side rails, riveted upper flanges

Cooling

Radiator: Tube and fin type

with fan and viscous clutch

Frame mounted fuel cooler

Clutch

Fluid hydrokinetic coupling

with lock-up clutch

Cab Interior

Flame resistant

interior trim

Vinyl floor matting Pillar

mounted entrance grab

handles both sides SRS

airbags driver and

passenger

Seats (all cloth)

Driver's fully adjustable

seat with head restraint

Dual passenger seat

with folding back

Driver and outer

passenger retractable

diagonal seat belts,

with pre-tensioner

Centre seat lap belt

Vision

Large foldable

door mirrors

Interior rear view mirror

on collapsible mounting

Driver and passenger

sun visors

Deep cut side window s

to reduce blind spots

Electric windows with

driver control

Heating & Ventilation

4-speed blower

Multiple cab vents

Axles

Front: Reverse

Elliott I-Beam

Rear: Banjo fully floating

Suspension

Front: Semi elliptical alloy

steel leaf springs with

hydraulic shock absorbers

Rear: Semi elliptical alloy

steel leaf springs with

hydraulic double acting

telescopic shock absorbers

and anti roll bar

Steering

Recirculating ball type

with full integral hydraulic

power assistance

Tilt and telescopic

steering column

Brakes

System: ABS divided

hydraulic, vacuum servo

assisted with ASR +

EVSC Front: 293mm

ventilated discs with

asbestos-free pads

Rear: 275mm

ventilated discs with

asbestos-free pads

Park: Mechanical drum

brake rear of transmission

Instruments

Speedometer with

odometer and trip

Rev counter

Fuel gauge

Engine coolant

temperature

Gearshift indicator display

Multi information display

provides data on

servicing, emissions and

fuel economy

Switches & Electrical

Steering column

mounted combination

switch for indicators,

headlamps (high beam),

side and rear fog lights

Wiper and washer (2-

speed and intermittent)

Steering wheel horn

Engine idle control

Hazard lights

Headlamp levelling

Interior light

Key operation for quick

cold start, start and

stop Engine quick

warm-up Cigarette

lighter Central locking

Reverse warning

DPD operation

Front fog lights

EVSC off

ASR off

Exhaust brake

Heater stage

Easyshift gearbox

emergency override

Gearbox engage

drive fast/slow

Warning/Indicator Lamps

Battery charge

Oil pressure

Low fuel

Glow plug operation

High beam and

indicators Parking brake

on Fuel/water separator

Check engine

DPD operation

Engine over

heat Adblue level

EVSC

ABS

SRS/airbag

Front and rear

fog SVS

ECONO mode

1st gear start

Exhaust brake

operation Seat belt

Brake system

Brake vacuum loss

Tool Kit

Jack, with a small

selection of hand tools

Radio

DAB Radio / CD

Player package

Storage Space

Compartment box

Centre console tray

Door pockets

Centre fascia pocket

Pop out type cup holder

Overhead roof shelves

Drivers seat back pocket

Card holder

Ancillaries

Starter: Reduction

type 24 V – 4.0kW

Alternator: 24 V – 50

Amp Quick Start: 4 glow

plugs on start relay

Battery: 2 x 12 V – 75

AH (maintenance free)

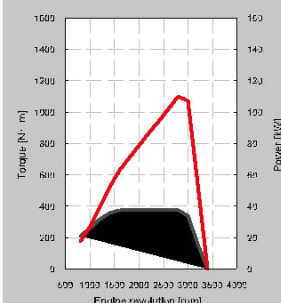

The following optional items are available:

- Isuzu Branded Mats
- Satellite Navigation
- Reversing Aids
- Digital Tachograph
- Road Speed Limiter
- PTO Switch
- Telematics
- Aerodynamic Body Kits

For further information please contact your local dealer, ring us directly on

01 4194500

or visit our website

www.isuzu-ireland.com

Isuzu Ireland,
Naas Road,
Dublin 12.

ISUZU

