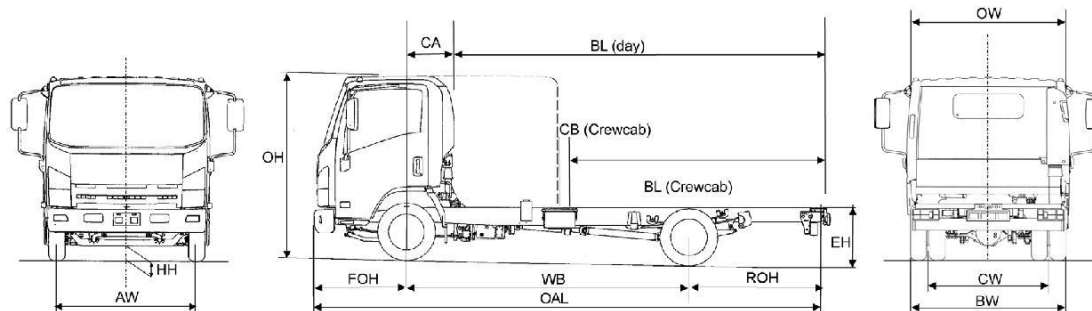
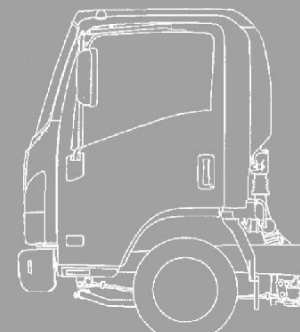

## ISUZU N75.190

## 7.5T GVW

(Manual transmission) 4x2 rigid

EURO VI

Standard vehicle  
plated weights (kg)

GVW	7500
GTW	8250
GTW Optional	11000

## Axle design weights (kg)

Front	3100
Rear	6000

## Weights (kg)

Cab type		day	day	day	crewcab
Wheelbase	WB	3365	3815	4475	4475
Vehicle Mass Unladen	Front	1830	1860	1930	2090
	Rear	1000	990	975	1070
Total		2830	2850	2905	3160
GVW		7500	7500	7500	7500
Max. Permissible Trailer Weight		3500	3500	3500	3500
Body & Payload Allowance		4670	4650	4595	4340

## Dimensions (mm)

Overall Length	OAL	5985	6635	7815	7815
Overhang - Front	FOH	1110	1110	1110	1110
Overhang - Rear	ROH	1510	1710	2230	2230
Cab Gap	CB	170	170	170	71
C/L Front Axle to Rear of Cab	CA	550	550	550	1574
Recommended Body Length	BL	4267	4876	6096	5029
Chassis Frame Width		850	850	850	850
Recommended Body Width		2286	2286	2286	2286
Recommended Maximum Body Width		2387 <sup>†</sup>	2387 <sup>†</sup>	2387 <sup>†</sup>	2387 <sup>†</sup>
Cab Width	OW	2040	2040	2040	2040
Overall Height (Unladen)	OH	2265	2265	2265	2260
Chassis Height (Unladen)	EH	805	800	780	780
Minimum Road Clearance	HH	190	190	190	190
Track - Front	AW	1680	1680	1680	1680
Track - Rear	CW	1650	1650	1650	1650
Rear Axle Width	BW	2129	2129	2129	2129

<sup>†</sup> Wide mirror arms apply at extra cost

1. Unladen weights excludes driver, fuel, Ad Blue. Includes spare wheel + carrier (Tolerance ± 3%).  
 2. Body lengths are given as a guide only. Bodybuilders are responsible for ensuring all legal requirements are met.  
 3. Maximum body lengths are calculated to remain within the maximum permitted overhang of 60% of the wheelbase. Cab gaps may vary.  
 4. Isuzu Ireland shall have no liability whatsoever should the information supplied have incorrect data, descriptions or illustrations.

## ISUZU N75.190

## 7.5T GVW

(Manual transmission) 4x2 rigid

EURO VI

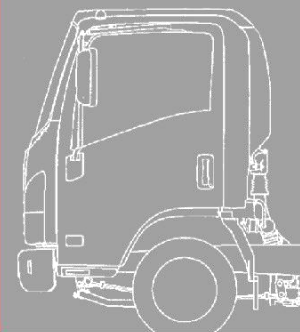

## Mechanical Specification (standard equipment)

**Engine 4HK1TC**

Isuzu turbo intercooled  
OHC 4 cylinder diesel  
(Euro VI)

Bore: 115mm

Stroke: 125mm

Capacity: 5193cc

Max Power: 140kW

(190 PS) at 2600rpm

Max Torque: 510Nm

betw een 1600-2600rpm

Injection Type: Common rail

Euro VI Compliance: EGR-  
(Exhaust Gas Recirculation)  
with DPD (Diesel  
Particulate Diffuser) SCR  
Adblue and OBD

**Fuel Tank**

Capacity: 92 litres

Ad Blue: 16 litres

**Transmission**

6 speed manual  
synchromesh MZZ6F  
overdrive

Ratios:	1st	6.369:1
	2nd	3.767:1
	3rd	1.966:1
	4th	1.355:1
	5th	1.000:1
	6th	0.782:1
	reverse	6.369:1

Rear Axle Ratio: 4.10:1

Tyres: 215/75 R17.5 radial,

Wheels: 6.00J x 17.5,

6-stud

**Cab Exterior**

Aerodynamic Isuzu

Hexapod design w hite  
all-steel w ith roof outline  
markers

Manual tilt to 45 deg. day

cab semi-fixed crew cab

Chrome radiator grille

Laminated w indscreen

Plastic resin non-slip entry  
steps

90 deg. opening doors

Zinc galvanised frame

structure

Steel reinforced composite

front bumper w ith fog and

daytime running lamps

2 halogen head lamps w ith

indicators

Front mudguards w ith

spray suppression

Keyless door entry and

immobiliser

Aluminium rear bumper

**Frame**

Parallel ladder type  
channel section straight  
side rails, rivet less upper  
flange

**Cooling**

Radiator: Tube and fin type  
w ith fan and viscous clutch  
Frame mounted fuel cooler

**Clutch**

325mm diaphragm type  
w ith hydraulic actuation

**Cab Interior**

Flame-resistant interior  
trim

Vinyl floor matting

Pillar mounted entrance

grab handles both sides

SRS airbags driver and

passenger

**Seats (all cloth)**

Driver's fully adjustable  
suspension seat w ith head  
restraint (optional on crew  
cab)

Dual passenger seat,  
folding back centre w ith  
tray

Driver and outer

passenger retractable

diagonal seat belts, w ith

pre-tensioner

Centre seat lap belt

4-seat passenger (crew

cab) w ith lap belts

**Vision**

Large foldable, heated

mirrors

Interior rear view mirror

on collapsible mounting

Driver and passenger sun

visors

Deep cut side w indow s to

reduce blind spots

Electric w indow s w ith

driver control and lock

**Heating & Ventilation**

4-speed blow er

Multiple cab vents

**Axles**

Front: Reverse Elliott

I-Beam

Rear: Banjo fully floating

**Suspension**

Front: Semi-elliptical alloy  
steel leaf springs w ith  
hydraulic shock absorbers  
and anti-roll bar

Rear: Semi-elliptical alloy  
steel leaf springs w ith  
hydraulic shock absorbers  
and anti-roll bar

**Steering**

Recirculating ball type  
w ith full integral hydraulic  
power assistance

Tilt and telescopic steering  
column

**Brakes**

System: ABS Power  
assisted divided

hydraulic, Vacuum Servo

w ith electronic brake

distribution and anti slip

regulation, Electronic

Vehicle Stability Control

Front: 310mm ventilated

discs w ith asbestos free

pads

Rear: 310mm ventilated

discs w ith asbestos free

pads

Park: Mechanical drum  
brake rear of transmission

**Instruments**

Speedometer w ith

odometer &amp; trip

Rev counter

Fuel gauge

Engine coolant temperature

Multi information display

provides information on

servicing, emissions and

fuel economy

Digital Tachograph

**Switches & Electrical**

Steering column mounted

combination switch for

indicators, head lamps

(high beam), front and

rear fog lights

Wiper and washer (2-speed

and intermittent)

Steering wheel horn

Engine idle control

Hazard lights

Head lamp levelling

Interior light

Heated mirror

Key operation for quick

cold start, start and stop

Engine quick warm-up

Cigarette lighter

Central locking

Reverse warning

DPD engage

EV SC off

ASR off

Exhaust brake

Heater stage

Electronic vehicle speed

limiter set at 56mph

(90kph)

**Warning/Indicator Lamps**

Battery charge

Oil pressure

Low fuel

Glow plug operation

High beam and indicators

Parking brake on

Fuel/w ater separator

Check engine

DPD operation

Engine over heat

Adblue level

EV SC

ABS

Exhaust brake operation

Front and rear fog

SVS

Seat belt

Brake system

SRS air bag

Brake vacuum loss

**Tool Kit**

Jack, w ith a small

selection of hand tools

**Radio**

DAB Radio/CD Player

package

**Storage Space**

Compartment box

Centre console tray

Door pockets

Overhead roof shelf

Storage bin (behind seats)

Card holder

**Ancillaries**

Starter: Reduction type

24 V – 4.5kW

Alternator: 24 V – 80 Amp

Quick Start: 4 glow plugs

on start relay

Battery: 2 x 12 V 115 AH

(maintenance free)

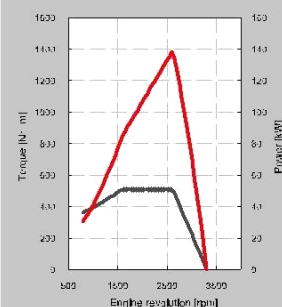
**The following optional items are available:**

- Isuzu Branded Mats
- Aerodynamic Body Kits
- Satellite Navigation
- Reversing Aids
- PTO Switch
- Telematics

For further information  
please contact your local  
dealer, ring us directly on

**(01) 41 94500**  
or visit our website  
[www.isuzu-ireland.com](http://www.isuzu-ireland.com)

**Isuzu Ireland**  
Naas Road  
Dublin 12

**ISUZU**

